

Electrochemical Methods to Measure the Corrosion Potential of Flux Residues

Mike Bixenman, DBA, David Lober, Anna Ailworth, Kyzen Corporation
Bruno Tolla, Ph.D., Jennifer Allen, Denis Jean, Kyle Loomis, Kester Corporation

Published in the 2017 IPC Apex Expo Technical Conference

Abstract

Reliability Expectations of Highly Dense Electronic Assemblies is commonly validated using Ion Chromatography and Surface Insulation Resistance. Surface Insulation Resistance tests resistance drops on both cleaned and non-cleaned circuit assemblies. It is well documented in the literature that SIR detects ionic residue and the potential of this residue to cause leakage currents in the presence of humidity and bias. Residues under leadless components are hard to inspect for and to ensure flux residue is totally removed. The question many assemblers consider is the risk of residues that may still be present under the body of components.

A recent research study¹⁰ of both flux activator systems and cleaning under bottom terminated components found that different no-clean flux packages have chemical properties that induce failure at different rates. The study also found that residues that were not fully cleaned under leadless components could be a reliability risk. Electrochemical methods (EIS) provide insight into the corrosion potential of a residue, in this case, flux residue. Electrochemical methods have not been commonly used for assessing corrosion potential on electronic devices. The purpose of this research study is to run Electrochemical Methods on the four flux systems used in the SIR study to determine if EIS data findings have commonality on the SIR data findings.

Introduction

The activity of flux residues on the surface and under component terminations is an important factor in controlling the reliability of an electronic assembly. Prior to the reflow process, surfaces to be joined are treated with flux to remove oxides and other contaminants in an effort to promote wetting and good solderability. After a reflow process, intermetallic compounds form new solid phases at the solder connection, ensuring mechanical strength and electrical and thermal conductivity. The fluxing of metal surfaces is accomplished through a specific class of components called activators, whose action is modeled through the following complexation (1) and disproportionation (2) reactions:

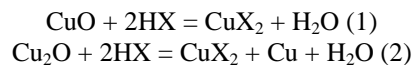

Therefore, organometallic complexes of Cu (CuX_2), or other metals interacting with the flux (solder, surface finish, conductive traces ...) are typical constituents of the soldering residue produced during reflow². Aside from the fluxing reaction products, these residues can also contain unconsumed activators, as well as dehydration and decomposition products. The composition, characteristics, and activity of the residues are governed by the chemical nature of the activators, as well as the assembly process and the environmental conditions under which the final assembly is operated¹.

While halide-free fluxes are popular alternatives to halogenated fluxes, due to environmental concerns, the behavior of the carboxylic acids can be relatively more complex³. The fundamental differences in thermal stability, metal complexes reactivity and polarity result in significant changes in residue properties. Also, the incomplete removal of oxides or surface reoxidation may prevent gases from escaping the liquid solder and give rise to large voids and pockets of active flux residue⁴.

In this work, electrochemical methods were used to examine the corrosion potential of the four flux activators used for the SIR study. Solder connections were printed on copper coupons. The dynamic redox behavior of the flux residue on Cu OSP and SAC305 was evaluated using electrochemistry to quantify both acid-base and redox kinetics as a function of the four flux types. Electrochemical methods using Electrochemical Impedance Spectroscopy, Linear Polarization Resistance (LPR) and Tafel constant analyses were performed on the four flux residues used within this study. The Electrochemical methods were compared to the SIR study on four flux activators using a Non-Standard Test Vehicle. The electrode oxide removal and electrochemical surface analysis were used to characterize surface reactions and their kinetics.

Research Objective

The objective of this study is to understand the chemical and electrochemical behaviors of flux residues from various activator packages. A previous study using SIR testing of residue under the body of leadless components found resistance

drops based on the activator package within the flux composition, reflow conditions and cleanliness of the residues trapped under the bottom termination. Electrical leakage and dendritic growth could be matched to these conditions. Using the four activator packages studied in the SIR research, electrochemical methods will be run to determine the corrosion potential of the activators used within the four solder pastes. The findings from this electrochemical study will be compared to the SIR study to determine if there is a correlation to risk factors associated with the activator package used in the solder paste formulation. A summary of these SIR findings are included in this paper to provide the readers with the necessary technical background¹⁰.

SIR Research of Four Flux Activators using a Non-Standard Test Vehicle

The primary purpose of a flux is to promote the wettability and enable the formation of intermetallic alloys. A flux must be stable over the reflow spectrum with slow degradation rate at soldering temperature. The use of halogen-free fluxes has become a new requirement due to environmental concerns of halide bearing fluxes.

The major ingredients in flux are solvents, vehicles (high-temperature phases), activators, surfactants, viscosity modifiers and tackifiers. The flux must be capable of reacting with the metal oxide, promote solder flow, and protect against re-oxidation during the soldering process in order to enable a strong metallurgical bond. Typical reactions at the metal surface can be complicated including dynamic acid-base, oxidation - reduction, complexation and adsorption reactions. The kinetics of flux redox reactions can be studied by comparing potentiodynamic polarization curves of the residues onto a Cu coupon.

A non-standard, highly-customized, test board was designed to study the surface insulation resistance responses of flux residues formed under leadless component terminations. A summary of the test board and results previously presented include:

1. Board surface finish: OSP
2. Resistivity sensor traces placed under various low standoff devices
3. Copper weight: 1 oz. copper
4. Vias under QFNs: 20 mils or smaller non plated
5. Solder mask: LPI, 8 μ m min
6. 3 Fiducials, 50mils
7. Board thickness: 62mils

Several low standoff devices were selected to study the effects of components architectures

- QFN44 and QFN100

Comparatively less complex and more open structures, minimizing the restrictions on solvent outgassing were also included. The selected devices were:

- BGA100 with 0.8mm pitch
- 2512, 1210 and 0805 Resistors

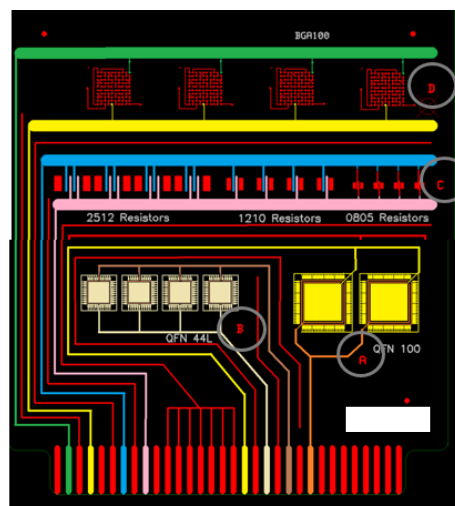

Figure 1: SIR Flux Reliability Test Board

The pin out shown was designed for compatibility with a 4 channels B24 connector wiring harness (A, B, C, and D). This mitigates the risks of cross-contaminations from hard-wiring the board with flux cored solder wires, as has been experienced in the past.

Channel D: This channel collects local SIR data under the BGA components. The board layout complements the internal daisy chain of each BGA to form the SIR electrical gap between selected balls under the devices (Figure 2).

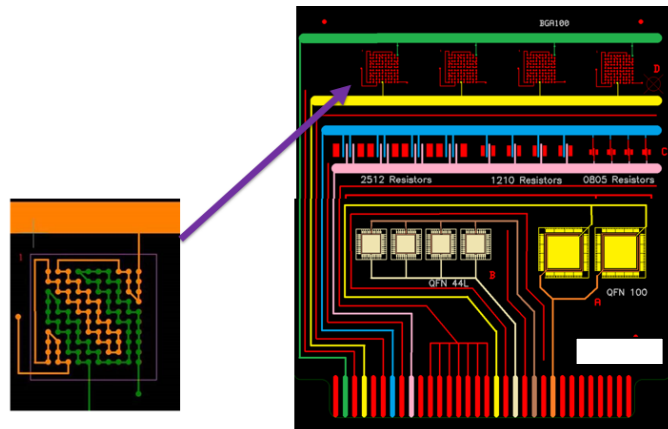

Figure 2: BGA Daisy Chain

Channel C: This channel collects local SIR data under the Resistors. Sensors are made of interdigitated traces located under the central body of the 12 passive devices. Solder paste was deposited on the sensor traces in addition to the resistor terminations, in order to ensure flux connections between the traces (Figure 3).

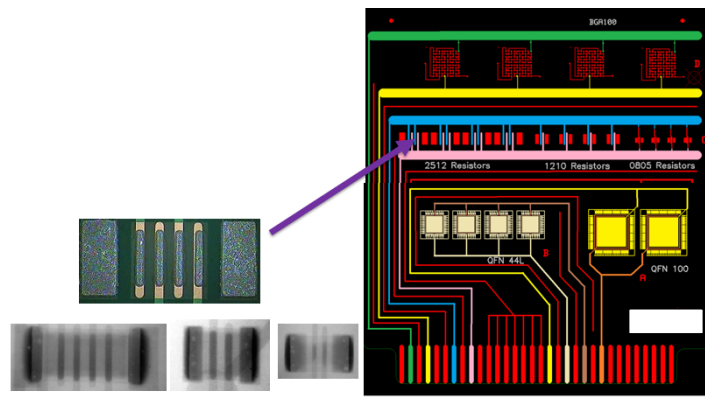

Figure 3: Passive Sensor Traces

Channel B: The looped sensors under each QFN44 device are located in the space between the central thermal pad and the perimeter I/Os (Figure 4). The loop is biased against the I/O and against the central pad.

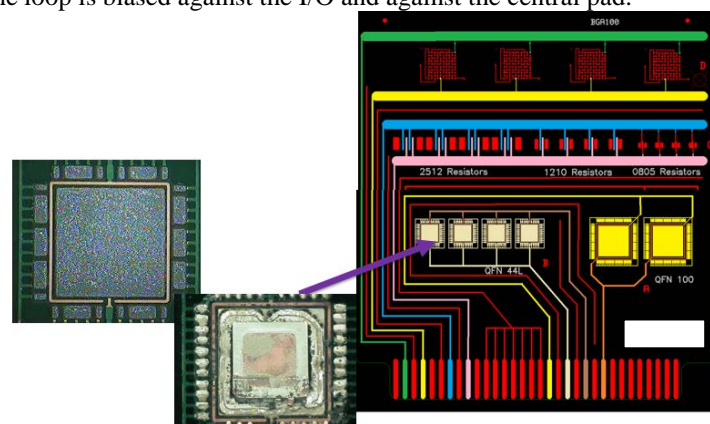

Figure 4: QFN 44 Sensor Traces

Channel A: This channel has a similar set up as Channel B to measure the local SIR values in the spacing under each QFN100 device, except for a more complex sensor loop geometry to insure a voltage gradient in the same range as other devices under test (Figure 5).

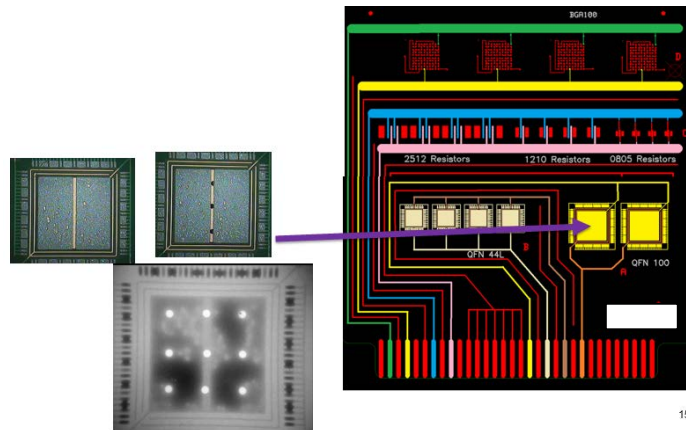

Figure 5: QFN 100 Sensor Traces

The IPC SIR Test method for open format B24 test boards (IPC-TM-650 §2.6.3.7) directs the user to apply an electrical bias of 25 V/mm (DC) between adjacent parallel traces. Since a broad range of line spacing and pitches is found on the customized board, the bias voltage was optimized to reach an acceptable range across components, while keeping the ability to study the impact of voltage gradients (Figure 6).

Sensor	Gap [mm]	Field Strength [V/mm]			
		25.0	31.5	16.0	10.0
reference, IPC B24	0.50	25.0			
reference, IPC B25	0.32		31.5		
2512	0.50	25.0	20.0	16.0	10.0
1210	0.34	36.6	29.3	23.4	14.6
0805	0.18	70.3	56.2	45.0	28.1
BGA100	0.35	35.7	28.6	22.9	14.3
MLF44 loop-I/O	0.13	93.0	74.4	59.5	37.2
MLF44 loop-center	0.14	91.6	73.2	58.6	36.6
MLF100 loop-I/O	0.29	43.8	35.0	28.0	17.5
MLF100 loop-center	0.29	43.7	35.0	28.0	17.5

Bias Voltage, VDC=	12.5	10	8	5
--------------------	------	----	---	---

Figure 6: Local field strengths under components for various applied voltage biases

Flux Activators

Over the past 25 years, the development and propagation of no-clean soldering materials that leave low levels of ionic residue post soldering has improved the reliability of electronic assemblies. With higher functionality using smaller design features, electronic hardware populated with leadless components has emerged. Leadless components are soldered on planar pads. As the component reduces in size, the sphere size of the solder paste and thickness of the soldering deposit reduces. This requires less solder flux availability to remove oxidation layers and protect against re-oxidation during the reflow soldering step. In relation to this miniaturization trend, the complexity of the assembly, in terms of layouts, form factors and component heterogeneities has increased. An aggravating factor is the low standoff distance from the board to the bottom of the component. With lower standoff gaps, flux may not have an adequate channel to outgas. Flux residues can be left inside the assembly. Reliability depends on the reactivity of no-clean post reflow residues under environmental stresses. Figure 7 illustrates the various contaminants that can be found on the surface of the PCB and under components when exposed to harsh environments.

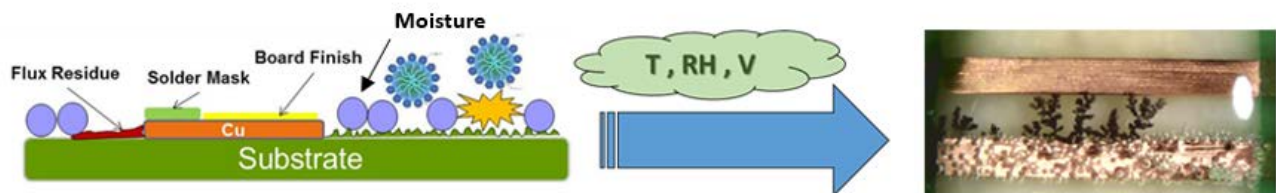

Figure 7: Flux Residue Trapped under Leadless Components with Environmental Stresses

Four low residue solder pastes using different flux activators were studied

1. Flux Activator #1: High Reliability Zero Halogen package
2. Flux Activator #2: Standard Zero Halogen package
3. Flux Activator #3: Activator #1 package doped with halogenated organic compounds
4. Flux Activator #4: Activator #1 package dopes with halides

Zero Halogen solder pastes (meaning non-intentionally added, in contrast to Halogen-free) substitute the halogenated activators using a blend of weak organic acids (RCOOH) and organic amines (RNH₂, RR'NH, RR'R''N). The fluxing reaction for the former is described in Figure 8:

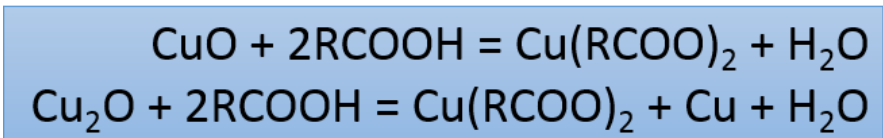

Figure 8: Fluxing mechanism of a weak organic acid

The electrochemical migration phenomenon resulting from the interaction between the residue and its environment then proceeds as follows:

1. Formation of an electrolytic path between conductors. Chemical impurities have a critical influence on ionic conduction at the surface of epoxy laminates. Their relative impact primarily depends on their moisture sensitivity.
2. Electrodisolution of metallic compounds. This reaction is mediated by the chemical compounds present in the system. The strength of the complexes thus created catalyzes this reaction.
3. Ion transport of the charged metallic complexes takes place within the electrical field. The voltage gradient (Bias / distance) between the polarized electrodes, and the stability of the metal complexes in this interstitial space are the key factors governing the dendritic growth.
4. Electrodeposition of the metallic complex : reduction of the metal complex at the cathode
5. Dendritic growth propagation from the cathode to the anode occurs based on the strength of the electric field and the electrostatic interaction between the dendrite and the complexes.

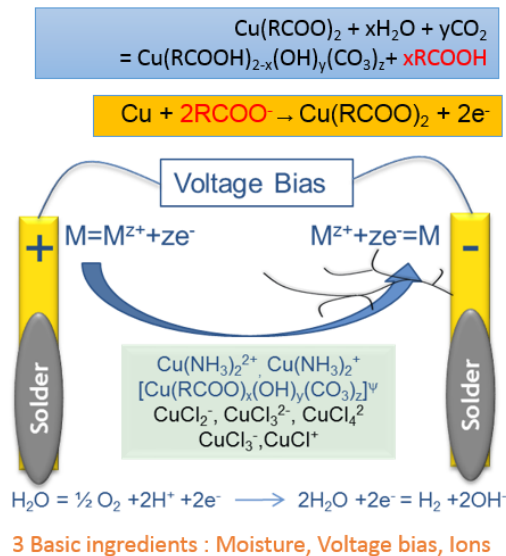

Figure 9: Residue impact on electrochemical migration

Halogenated activators are highly effective at removing oxidation from metal alloys. However, halogens also form strong Cu complexes that catalyze metal corrosion. Also, their residues are highly ionic and hygroscopic. In the presence of

moisture, these residues will hydrolyze and create a high potential for metal migration and dendritic growth Figure 10 provides an oxidation / reduction reaction pathway for a Chloride activator residue in the presence of moisture.

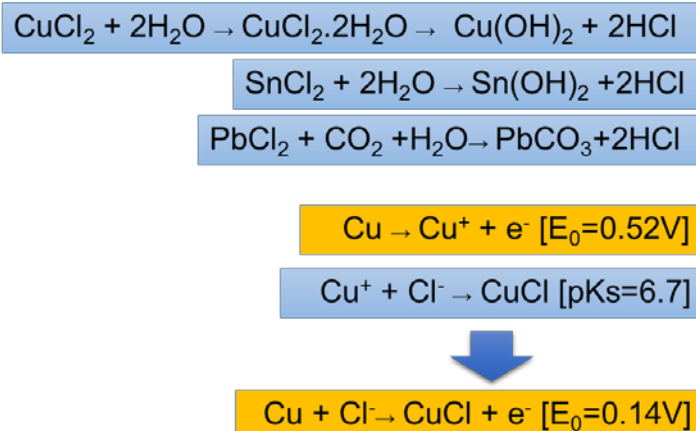

Figure 10: Halogenated Activator residue Oxidation/Reduction reaction

These effects can be somewhat mitigated by “trapping” the halogen element in a covalent bond, which will delay its activation to higher temperatures. Halides correspond to the ionic fraction of halogens in the flux formula. These are active at room temperature and pose an immediate reliability risk. Halogenated organic compounds present a delayed effect, but are still subject to the mechanisms reported in figure 10 once they have been activated. The role of the flux formulator is to balance these reactions, in order to minimize the corrosiveness and electrochemical migration effects in the end-use environment while keeping high fluxing performance levels.

SIR Test Results

The SIR values report resistivity values on test boards processed under the following conditions:

1. Reflow
 - a. Ramp-to-Spike
 - b. Soak
2. Cleaning
 - a. Not Cleaned
 - b. Partially Cleaned with some residue left under the bottom termination
 - c. Totally Cleaned

Activator #1 is a zero-halogen solder paste using a blend of weak organic acids, organic amines, corrosion inhibitors and antioxidants. Residue trapped under components showed different leakage effects based on the reflow profile tested. The flux residue from this solder paste showed greater erratic resistivity values when reflowed using the soak profile. Flux residues on not cleaned and partially cleaned test boards showed failures for the four components tested. Conversely, for the ramp to spike reflow profile, leakage potential was less erratic. On parts reflowed using the ramp to spike reflow profile, errant residue remaining under the component was less problematic.



Figure 11: Activator #1 SIR data for Not Cleaned, Partially Cleaned and Totally Clean Test Boards

Activator #2 is another zero-halogen solder paste designed for general market applications. In contrast to Activator #1, the soak profile data was better on partially and totally cleaned test boards. In regards to the not cleaned test boards, there were hard failures using both the ramp to spike and soak profiles. It is remarkable that this zero-halogen package presents the worse reliability performance of all activator packages in uncleaned conditions.

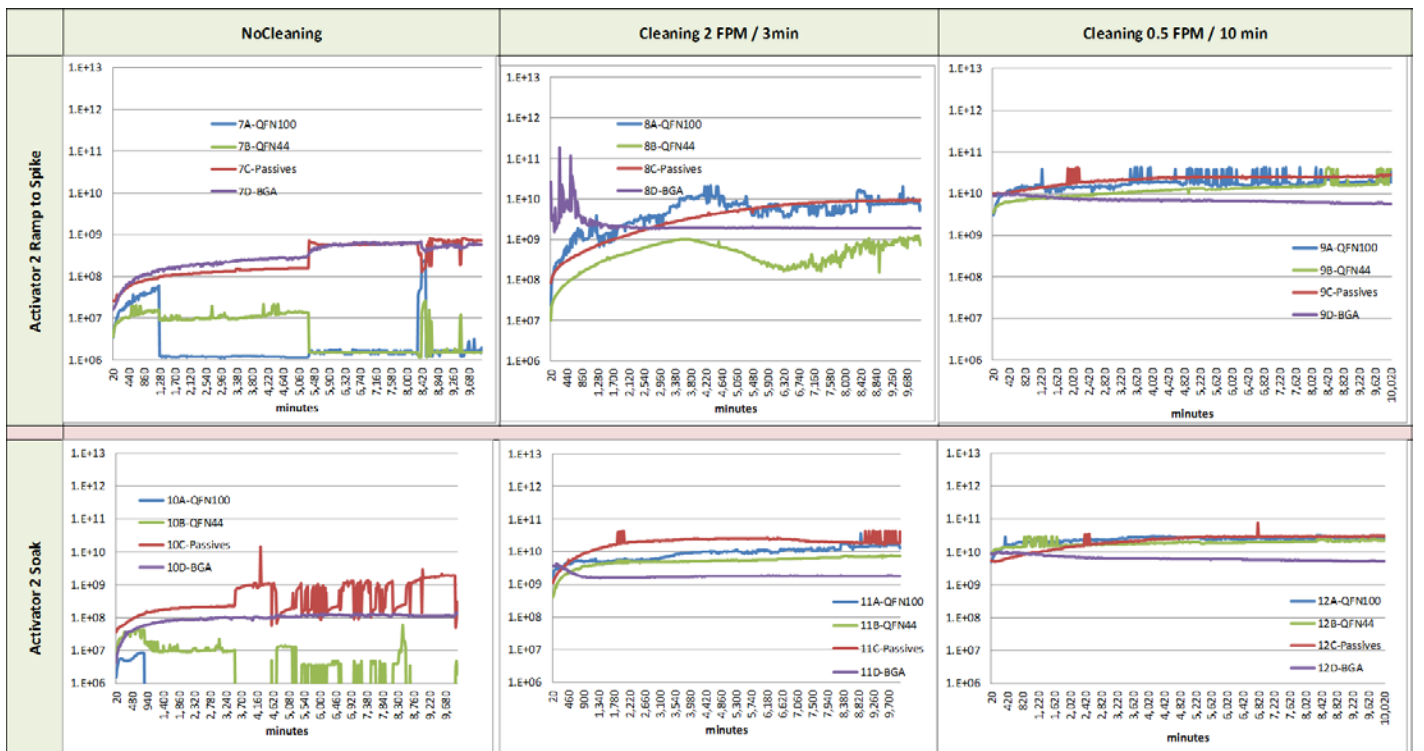

Figure 12: Activator #2 SIR data for Not Cleaned, Partially Cleaned and Totally Clean Test Boards

Activator #3 is a halogen based solder paste formulated with halogenated organic compounds using large doping levels in excess of 1,500 ppm. This solder paste showed the best reliability performance under components for the four activators used within this study. The interplay between chemical reactions, processing conditions and end-usage environments are well balanced for this flux formulation.

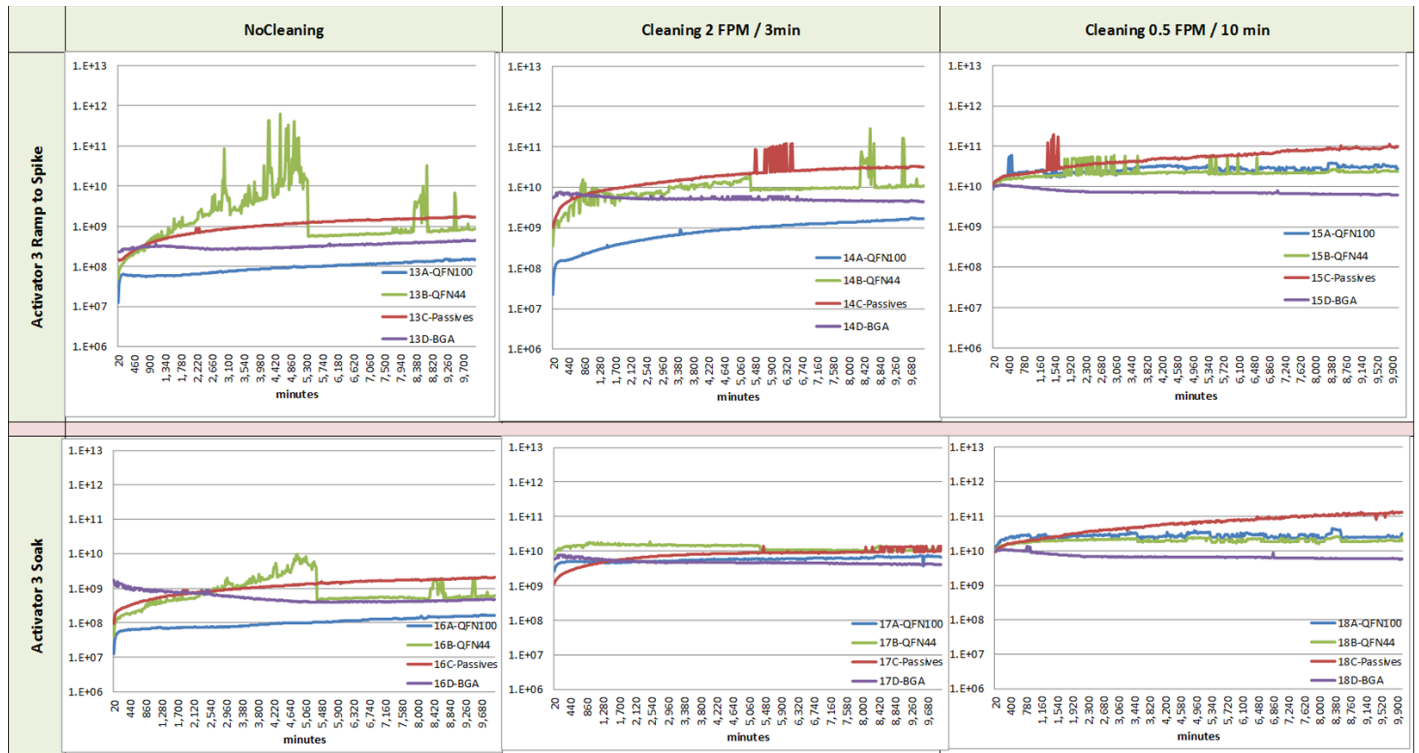

Figure 13: Activator #3 SIR data for Not Cleaned, Partially Cleaned and Totally Clean Test Boards

Activator #4 is a halogen based solder paste formulated with an ionic form of halogens (halides) using large doping levels in excess of 1,500 ppm. This activator had the worst overall reliability on test boards that were not thoroughly cleaned, consistent with our discussion of the failure mechanisms in the previous section. Electrochemical activity was independent of reflow conditions, due to the inherent thermal stability of the halides used in this formula.

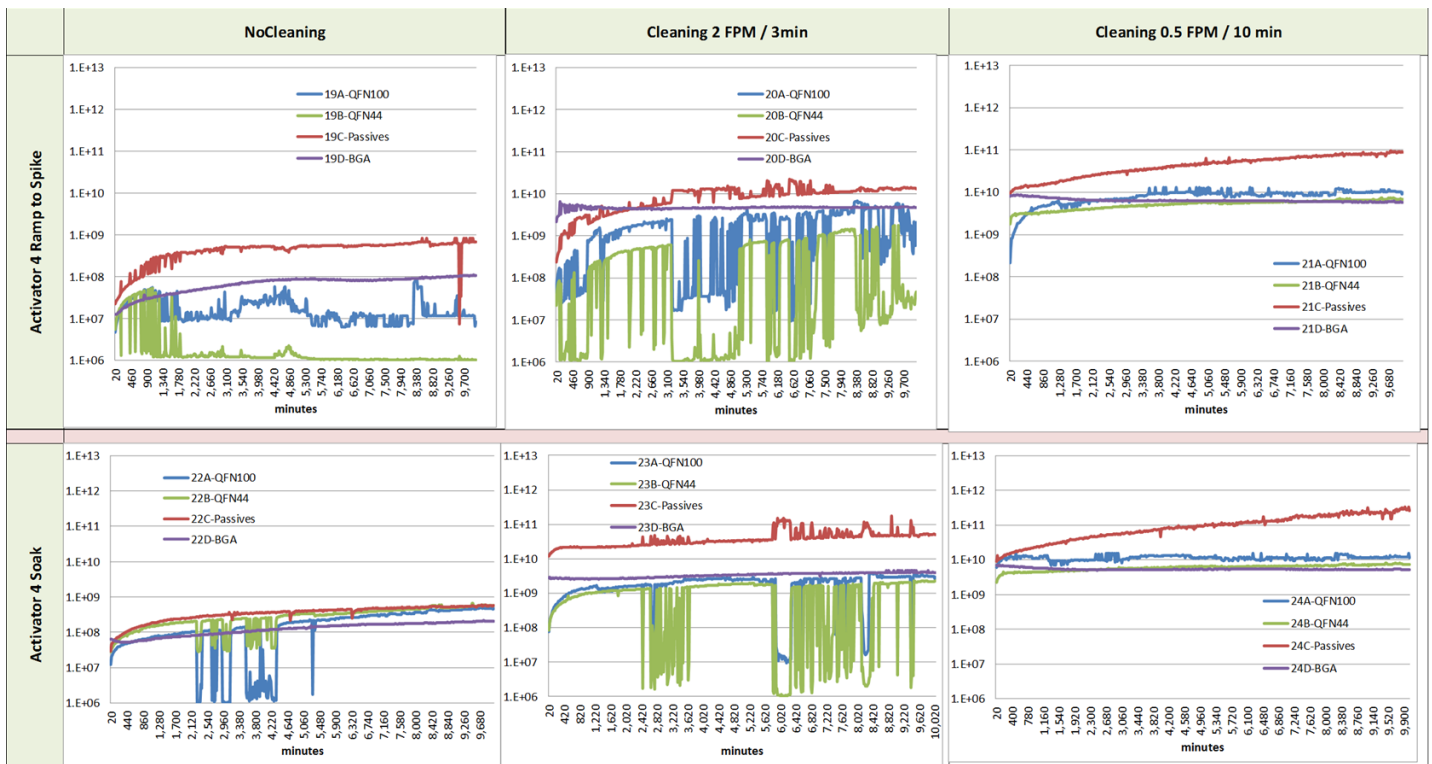

Figure 14: Activator SIR Data for Not Cleaned, Partially Cleaned and Totally Clean Test Boards

Electrochemical Research used to Measure Flux Residue Corrosion Potential

Corrosion is an electrochemical process. Many electrochemical techniques have been developed for taking corrosion measurements. Electrochemical corrosion measurements can be completed in minutes to hours since corrosion is accelerated by polarizing the sample. Low corrosion rates can be measured since low currents can be measured with potentiostat methods⁶. Methods are designed to evaluate both positive and negative currents (Figure 15).

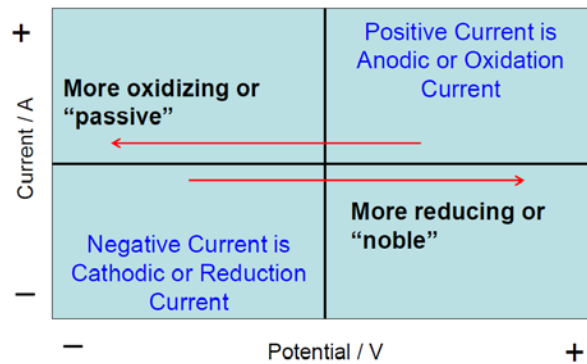

Figure 15: Anodic / Cathodic Current Measurements

Corrosion is thought of as the oxidation of a specimen. For this research, we are evaluating the activity of the flux residue left next to the soldered connection. The thinking is that the higher the activity of the flux residue, the greater the potential for metal migration and current leakage. Electrochemical techniques provide qualitative information about corrosion behavior in the form of passive, active, and stable conditions. Quantitative information is determined using Tafel constants to measure the corrosion rate.

E_{Corr} is defined as corrosion potential⁶. Corrosion takes place when a metal is immersed in a given solution (in this case, ionic residues from the flux mobilized with moisture). The electrolytic solution initiates electrochemical reactions at the surface of the metal. The reactions are characteristic of the metal – electrolyte interface, which can be defined as the electrochemical potential. The corrosion potential (E_{Corr}) corresponds to the open circuit potential (OCP) as the metal surfaces corrode freely. The potentiostat measures this potential versus a reference electrode.

Experimental: The four solder pastes used in the SIR study were printed onto Cu OSP coupons (Figure 16)

- Flux Residue next to the solder alloy (SAC305) was analyzed
- The test boards were reflowed using the ramp-to-spike profile
- A jumper wire was soldered to connect the instrumentation to the front side of the test board
- A flat cell style corrosion cell was used
 - One end contains a 1 cm diameter hole
 - Sample is pressed against opening to allow a known surface area to be exposed
 - Solder paste circles were lined up with that opening
- An Ag /AgCl /KCl reference electrode was used
- The electrolyte was DI water
 - Water was not de-aerated prior to use

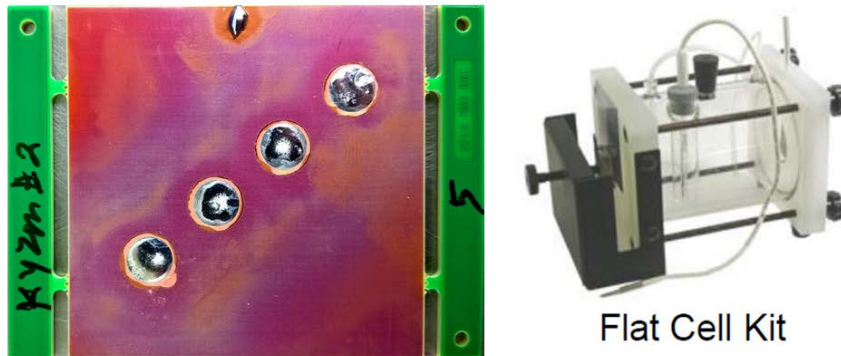

Figure 16: Image of Test Sample(s) measured with a Flat Cell

The results of the work are shown in the next section.

Results and Discussion

Open Circuit Potential (OCP) provides corrosion information that allows for the flux residue activity to be measured. A negative OCP means an electrode is more likely to corrode. A positive OCP means that the metal is more “noble” and less likely to corrode from the flux residue. The OCP for the four fluxes is shown in Figure 16. The OCP finds that Flux #4 is the most active, which correlates with the SIR data.

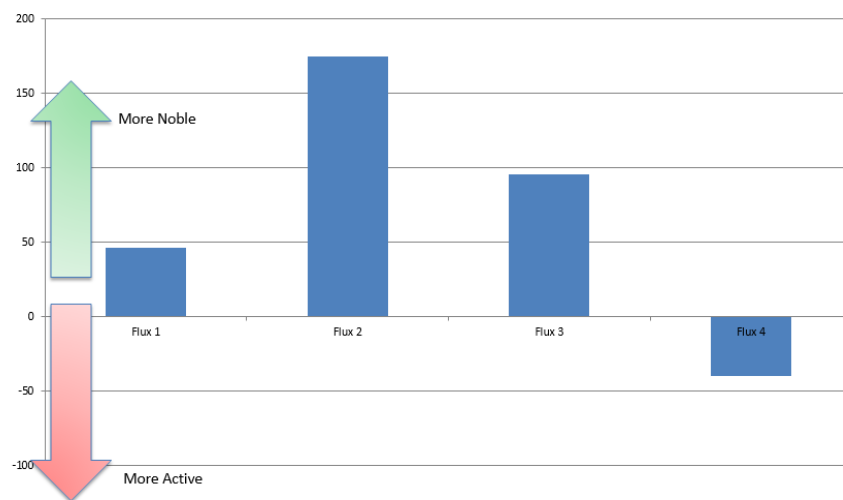

Figure 16: Open Circuit Potential for the Four Fluxes in this Study

Three electrochemical techniques were chosen to study the reactivity of the flux residues from the four solder paste activator systems.

1. Electrochemical Impedance Spectroscopy (EIS): The AC (alternating current) method uses voltage and current in a reverse direction. This test yields very little damage to the sample. The test provides detailed information about the corrosion mechanism. This is a non-destructive method.
2. Linear Polarization Resistance (LPR): LPR is a “narrow spectrum” DC technique. Potential is changed and it is the least invasive of all DC techniques. This method is usually considered non-destructive or minimally destructive. Around the OCP, the potential (resistance) and current are approximately linearly related. Potential is changed by no more than 20 mV. Ohm’s Law applies. The value of LPR indicates the tendency for the metal to corrode in the electrolyte. This method can be used with additional electrochemical data to provide a corrosion rate.
3. Tafel plot analysis: Potential is measured from 0 to 250 mV (anodic) and then from 0 to -250 mV (cathodic). This provides electrochemical constants that are required to calculate corrosion rate. The Tafel test is the most destructive of the techniques studied.

Electrochemical Impedance Spectroscopy (EIS)

Electrical resistance resists the flow of electrical current. EIS uses impedance to measure the ability of a circuit to resist the flow of electrical current⁷. Electrochemical impedance is measured by applying an AC potential to an electrochemical cell and then measuring the current through the cell. The response to this potential is an AC current signal. This current signal can be analyzed as a sum of sinusoidal functions. The impedance is expressed in terms of magnitude and phase shift. For a potentiostated electrochemical cell, the input is the potential and the output is the current. The EIS data for the four fluxes is shown in Figure 17.

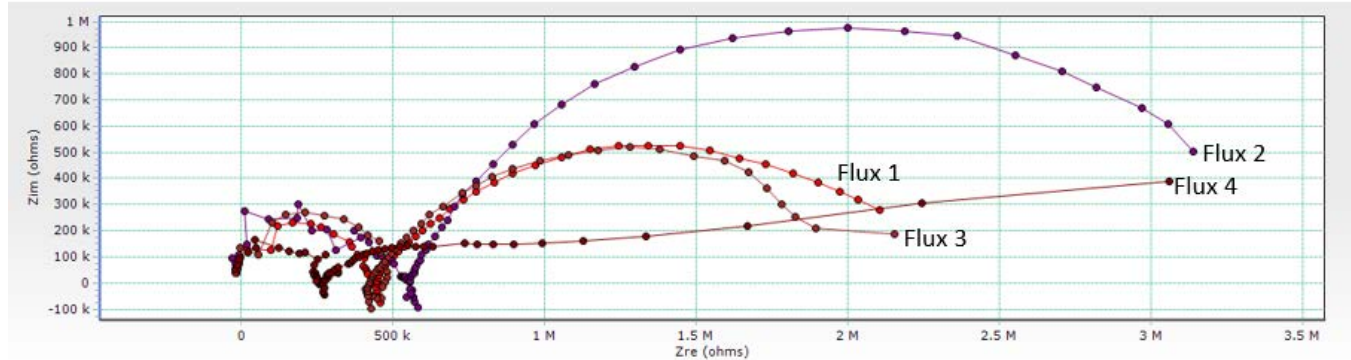

Figure 17: EIS data for the four fluxes

There is a connection between the peak Ohm reading of the second semicircle, the corrosion rate and corrosion resistance. The high peak Ohm values mean that the corrosion resistance is high, and the corrosion rate is low. Flux 2 has the largest peak Ohm at 3.118 MΩ, and it has the lower corrosion rate of 0.012187 MPY (Corrosion Rate). Flux 4 has the lower peak Ohm at 993 KΩ, and it has the highest corrosion value of 0.05206 MPY. The EIS data finds that the residues from all four fluxes have corrosion risks but with different corrosion resistance. Fluxes by design remove surface oxidation to enable a soldering process. To do so, activators are formulated into the flux formulations. The stronger the activator, the higher is the corrosion rate, as found by the EIS data. The data also finds that Flux 1, 2, and 3 provide a good deal of corrosion resistance. To trigger corrosion, the ionic residues within the flux residue must be mobilized with moisture. Flux 4 is different, in that this flux has the strongest ability to remove metal oxides at all temperatures, but it also has limited corrosion resistance.

Linear Polarization Resistance (LPR)

When a metal/alloy electrode is immersed in an electrolytically conducting liquid of sufficient oxidizing power, it will corrode by an electrochemical mechanism⁵. The process involves two simultaneous, complementary reactions. At the anodic sides, metal will pass from the solid surface into the adjacent solution and, in so doing, leave a surplus of electrons at the metal surface. The excess electrons will flow to nearby sites, designated cathodic sites, at which they will be consumed by oxidizing species from the corrosive residue. The corrosion current (I_{CORR}), generated by the flow of electrons from anodic to cathodic sites, can be used to compute the corrosion rate by the application of a modified version of Faraday’s Law where:

C=Corrosion rate in “mils per year” (MPY)

E = Equivalent weight of the corroding metal (g)

A = Area of corroding electrode (cm²)

d = Density of corroding metal (g/cm²)

The anodic and cathodic sites continually shift position, and they exist within a continuously conductive surface, making direct measurement of I_{CORR} impossible⁵. Small, externally-imposed, potential shifts will produce measureable current flow

(I) at the corroding electrode. The behavior of the externally imposed current is governed, as is that of I_{CORR} , by the degree of difficulty with which the anodic and cathodic corrosion processes take place. The greater the difficulty, the smaller the value of I_{CORR} , and the smaller the value of I for a given potential shift. At small values of E, I is directly proportional to I_{CORR} , and hence to the corrosion rate. The value E/I is known as the Polarization Resistance (Figure 18).

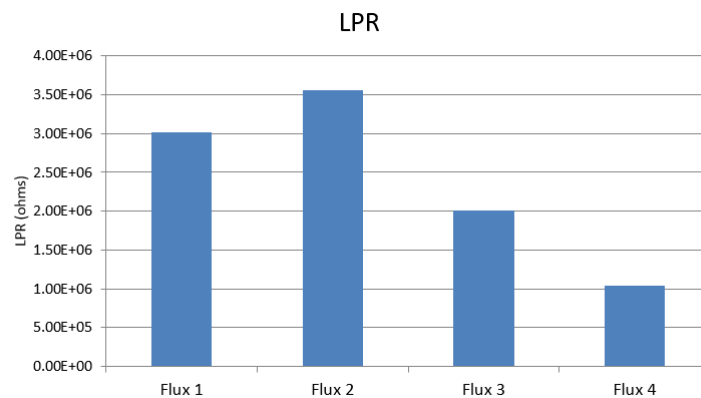

Figure 18: Linear Polarization Resistance Measurements for the Four Fluxes

The LPR data finds that Flux 1 and Flux 2 residues exhibit the highest corrosion resistance. Both of these fluxes are halogen-free fluxes. The data finds that Flux 3, a halide bearing flux, exhibits lower corrosion resistance over Fluxes 1 and 2. Flux 4 exhibits the lowest corrosion resistance of the four fluxes tested. The LPR data findings provide an additional layer of valuable information that can be used to better understand the risks associated with the residue. When considering the SIR data, the data findings offer some unique correlations to the activity of the flux and the potential risk of the residue trapped under leadless components. The LPR data provides an additional layer of SIR validation.

Tafel Constants

Most corrosion phenomena are of an electrochemical nature and consist of reactions at the interface between the metal and electrolyte solution⁹. In regards to electronic leakage, a thin film of moisture on a metal surface forms the electrolyte for atmospheric corrosion. Dendritic growth normally occurs at a rate determined by equilibrium between opposing electrochemical reactions. One reaction is the anodic reaction, in which a metal is oxidized, releasing electrons into the metal. The other is the cathodic reaction, in which a solution species is reduced, removing electrons from the metal. When these two reactions are in equilibrium, the flow of electrons from each reaction is balanced, and no net electron flow (electrical current) occurs. The two reactions can take place on one metal or on two dissimilar metals that are electrically connected.

Calculation of corrosion rates requires the determination of corrosion currents. When reaction mechanisms for the corrosion reaction are known, the corrosion currents can be calculated using Tafel Slope Analysis⁸. The Tafel plot is generated directly from the Butler-Volmer equation⁸. The corrosion potential is the open circuit potential of a corroding metal. The corrosion current and the Tafel constants can be measured from the experimental data. The Tafel equations predict a straight line for the variation of the logarithm of current density with potential. Currents are shown in semi-logarithmic plots known as Tafel plots.

Using polarization, the rate of a reaction is controlled by the rate at which reactants arrive at the metal surface⁹. Flux activators can alter the surface of the metal. Tafel analysis is performed by extrapolating the linear portions of a logarithmic current versus potential plot back to their intersection (Figure 18). The value of either the anodic or cathodic current at the intersection is I_{CORR} . The Potentiostat software performs numerical fit to the Butler-Volmer equation. The numbers β_a and β_c are empirical rate constants, the Tafel constants.

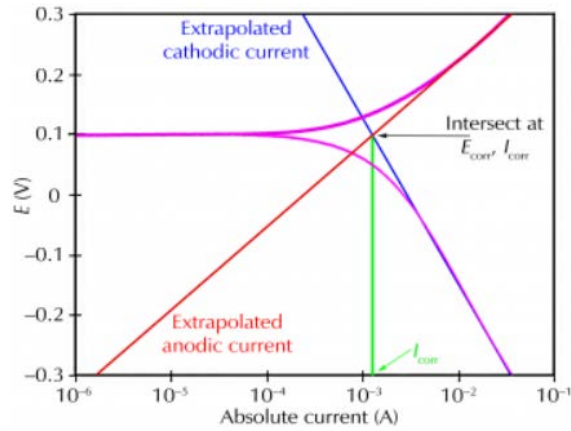

Figure 18: Tafel Analysis Example

Table 1 represents the Tafel constants for the four Flux activators within this study. Flux #4 has the highest corrosion potential, followed by Flux #3, Flux #1 and Flux#2. The Tafel chart in Figure 19 is a plot of the logarithmic values for the β_a (anodic) and β_c (cathodic) values. Flux 4 has the high E_{CORR} potential indicating that this flux was the most active of the four fluxes tested. The findings were consistent with the SIR data findings. Flux 1 and Flux 2, being halide-free were found to be highly active fluxes, but their corrosion rate was less than the halogenated fluxes.

Table 1: Tafel Constants for the Four Fluxes Analyzed

Flux	E_{corr}	I_{corr}	B_c Cathodic	B_a Anodotic	Corrosion Rate (MPY)
1	161.963	17.042	338.988	175.183	0.017803
2	181.724	11.666	319.809	204.051	0.012187
3	192.251	24.289	207.406	154.167	0.027357
4	241.231	49.837	443.018	198.52	0.05206

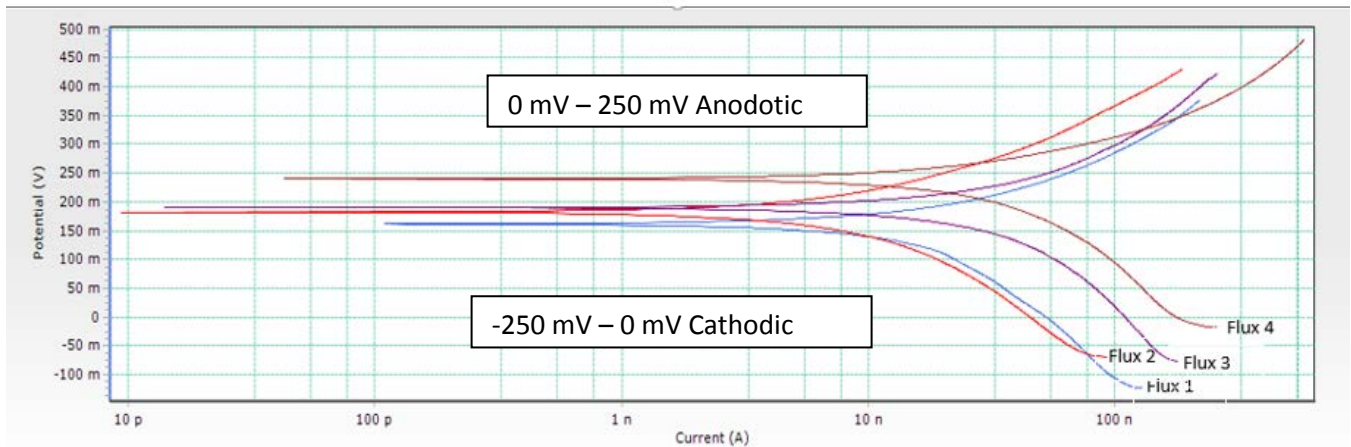

Figure 19: Tafel Plot of the Four Fluxes Analyzed

The anodic values represent the residues potential to resist leakage in the present of moisture. The cathodic values represent the residues potential to propagate corrosion. The Tafel plot anodic values indicate that each of the fluxes in this study have the potential to resist corrosion when in a stable environment. When the flux is mobilized with moisture, each of the fluxes tested have corrosion potential. The cathodic data finds that Flux 4 exhibits the higher corrosion rate followed by Flux 3, Flux 1 and Flux 2.

Conclusions from the Data Findings

Flux is an aid used within the electronic assembly industry to join metals needed to create a metallurgical bond. Reliability of the flux residue left after the soldering process depends on the reactivity of the post reflow residues when contacted with moisture and electrical bias. The activity of the flux residue on the surface and under component terminations is an important factor in controlling the reliability of an electronic assembly.

To determine the corrosion potential of flux residue, IPC J-STD-004 and J-STD-005 specify several test methods. One of those test methods, IPC-TM-650 2.6.3.7 measures the surface insulation resistance to quantify the deleterious effects of fabrication, process or handling residues in the presence of moisture and bias¹¹. The test method measures the resistance between the cathode and anode on the component tested. The test method requires specifically designed test boards, instrumentation, humidity, bias and time. The length of the test is 168 hours.

EIS test methods are commonly used by many industries to test corrosion resistance and corrosion rates. Electrochemical corrosion measurements can be completed in minutes to hours since corrosion is accelerated by polarizing the sample. Electrochemical methods are not commonly used to measure the corrosion resistance and corrosion rates of flux residue left on the assembly post soldering. The objective of this research was to evaluate the activity of the four fluxes used in the SIR study and to determine if EIS test methods find commonality of the corrosion rate for each of these four activator systems. We wanted to determine if the electrochemical corrosion measurements were similar to what was found from the SIR study.

The SIR study found a wide divergence based on the activator system used in the solder paste, the reflow conditions used to solder the assembly and the level of cleanliness. For each of the components represented on the test board, the SIR study provided current leakage potential from the activity of the residue that was left under the body of the component tested. There was a clear delineation between the activity of the flux post soldering, reflow conditions and cleanliness levels.

The EIS methods used on these four flux activators also found a wide divergence based on the activator system used within the solder paste based on the remaining flux residue. The EIS analysis only evaluated the flux residue on a copper coupon using the Ramp-to-Spike reflow profile. No cleaning was performed for this EIS study. The electrical leakage from the SIR values, on the four activator systems tested, showed a similar trend to the EIS values found in this study.

Electronic reliability data finds that corrosion takes place when a reactive metal comes in contact with active flux that is mobilized with moisture under bias. The electrolytic solution initiates electrochemical reactions at the surface of the metal. The data from this study found that reactions are characteristic of the metal – electrolyte interface. The corrosion rate and corrosion potential of the four flux activators was determined using EIS methods. The EIS data findings compared with the SIR data findings. More work is needed to better understand, validate and optimize EIS test methods. The data findings in this paper are a starting point.

References

1. Klein Wassink R.J. "Soldering in Electronics" Electrochemical Publications Ltd, 1989, ISBN: 0-901150-24-X.
2. B. Tolla, D. Jean, H. Bhavsar, Y. Shi, X. Wei. Reactivity of no-clean flux residues in electronic assemblies: A systematic study. Proc. SMTA International, Sept 27-Oct 1 (2015), Rosemont, IL, USA.
3. Qu, Guoying. (2013, May). Activity of Halide Free Flux at Copper and Tin Surface. Louisiana State University.
4. Yao, Keer et al. (2010). Modeling the failure of intermetallic/solder interfaces. *Intermetallics*. 18(8): 1603-1611.
5. Linear Polarization Resistance Monitoring (n.d.). Retrieved from <http://www.alspi.com/lprintro.htm>
6. Sheridan, L.B. (2014, Oct 13). DC and AC Corrosion Techniques and Applications. Ametek Scientific Instruments.
7. Gamry Instruments (n.d.). Basics of Electrochemical Impedance Spectroscopy.
8. Metrohm (n.d.). Measurement of Corrosion Rates. Metrohm.
9. Gamry Instruments. (n.d.) Getting Started with Electrochemical Corrosion Measurement. Retrieved from <http://www.gamry.com/application-notes/corrosion-coatings/basics-of-electrochemical-corrosion-measurements/>
10. Tolla, B., Allen, J., Loomis, K. & Bixenman, M. (2016, Sep). Reactivity of No-Clean Flux Residues Trapped under Bottom Terminated Components. SMTAI. Rosemont, IL.
11. IPC Association Connecting Electronics Industries. (2007, March). Surface Insulation Resistance. IPC-TM-65 2.6.3.7